

Instruction Manual

EW-SP505LAN combines a wide range of heating and cooling technology, easy to operate, accurate temperature control, strong anti-interference ability, suitable for a variety of heating and cooling equipment, fully automatic intelligent control system, our temperature sensor is moisture-proof, precisely manufactured and with more stable and reliable performance.

Specification

1. Operating Voltage: 220VAC±10 % ; 50HZ/60HZ
2. Outputs: Cooling 10A/220V/AC; Heating 10A/220V/AC
3. Power Consumption: ≤3W
4. Working Environment: -10 ~ 50°C; RH≤90%
5. Control Range: 0 ~ 40°C Factory setting: 20°C
6. Resolution: 0.1°C; Accuracy: ±0.5°C
7. Input Signal: 1-off NTC20K sensor
8. Sensor length: 2m
9. Overall Dimension: 155 (W) × 108 (H) × 34.6 (D) mm
10. Mounting size: 146 (W) × 99 (H) mm;

Display Panel

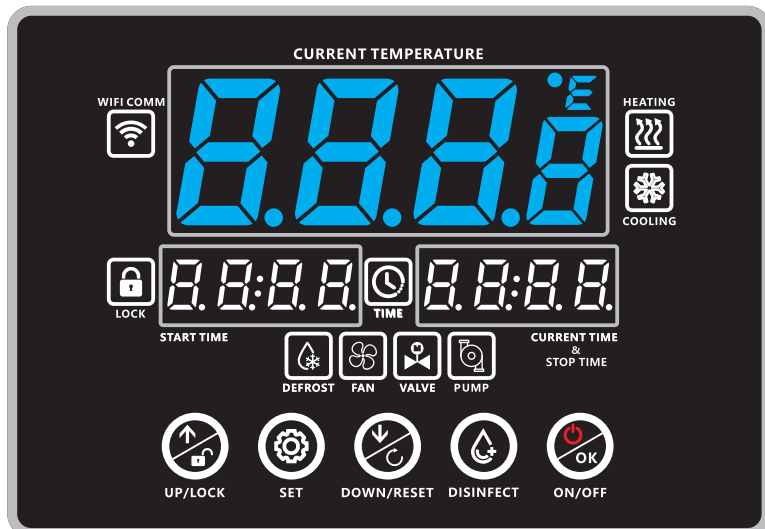

Installation Requirement

1. Please make sure that the power supply voltage meets the required voltage of the instrument. The deviation should be less than ±10 %.
2. The sensor should be kept away from the power cable.
3. Strictly distinguish the interfaces of the sensor, power cable and the relay output

Indicators and signs

Symbol	Sign	Status	Description	Symbol	Sign	Status	Description
	Cooling	off	refrigeration stops		Defrost	off	defrost stops
		on	refrigeration			on	defrosting
	Heating	off	heating stops		Defrost	off	fan stops
		on	heating			on	fan works
	WIFI	off	WIFI stops working		Four-way -valve	off	Valve is closed
		on	WIFI is working			on	Valve is open
	Time	off	start or stop time haven't set		Pump	off	Pump stops
		on	start or stop time have been set			on	Pump works
	Lock	on	Locked		Disinfect	off	stop disinfecting
	On/Off	-	"---" - shutdown mode			on	disinfecting
	Setting	off	non-setting mode	-	-	on	setting mode

Function description

1. Heating condition: When the water temperature ≤ Set temperature - Temperature return difference (d), the heating indicator is on and the heating start delay.
 - (a) Heating start: when the water temperature ≤ Set temperature - temperature return difference (d) and the compressor stop time ≥ Pt, four-way valve relay connects 10s before the compressor relay, then the compressor relay connects, then the fan relay connects, and the system enters heating state, heating indicator light is on.
 - (b) Stop Heating: When the water temperature ≥ set temperature, the four-way valve relay is disconnected, the compressor relay and the fan relay are disconnected, the system stops heating, and the heating indicator light flashes.
2. Refrigeration state: when the water temperature ≥ set temperature + return temperature (d), refrigeration indicator flashes, refrigeration starts with time delay.
 - (a) start refrigeration: when the water temperature ≥ set temperature + temperature return difference(d) and the compressor stop time ≥ "Pt", the compressor relay connects, then the fan relay connects, the system enters refrigeration state, the refrigeration indicator is on.
 - (b) stop refrigeration: when the water temperature ≤ set temperature, the compressor relay is disconnected, the fan relay is disconnected, the refrigeration stops, the refrigeration indicator flashes.
3. Defrosting status: the compressor and fan will stop before entering the defrost mode, and the defrost indicator is on.
 - (a) start defrosting: when the compressor runs under the heating state and continue to run the set time "dc", the fan and compressor will stop running, and after 1 minute, the compressor relay connects, and the fan and four-way valve relay will be disconnected. If "def=0", the fan relay will be connected, the compressor and four-way valve relays will be disconnected, the system enters defrost mode, and the defrost indicator is on.
 - (b) stop defrosting: when the defrost process reaches the set time "dt", the system will exit defrosting.

Operation Instruction

1. Switching operation (Note: the meter is in standby state when it is powered on, it needs to press the " " key to enter normal operation)

a) (Manual)

1. Power on: when the meter is under the "----" shutdown state, hold the " " key for 3 seconds, the meter enters the standby state, at this time the meter only displays the temperature, and does not enter the running state, the user needs to set the parameters, short press the " " key, the refrigeration or heating indicator blinks, the instrument enters the normal running state.

2. Shutdown: Hold the " " key for 3 seconds, the meter will display "----".

(b) (Automatic)

1. Power on: when the meter has set the start-up time, the instrument will automatically power on and run after the meter reaches the start-up time.

2. Shutdown: when the meter has set the shutdown time, after the meter reaches the shutdown time, the meter shuts down and displays "----".

2. Locking Function:

When it is locked, hold "upkey" for 3 seconds to unlock the meter along with buzzer sound.

The key will be locked automatically after 30s without any operation.

3. Temperature setting

a) Under normal running mode, press "SET" to display the set temperature (figure is flickering)

b) Then press "UP" or "DOWN" key to adjust the parameter values.

c) Hold "UP" or "DOWN" key to quickly adjust the parameter values.

4. User parameter adjustment method

(a) Press the "Set" key for more than 6 seconds until the temperature display the code "Pass" and the left digital tube displays "000", then press the "up" or "down" key to enter the password, after that, press "OK" or wait for 6 seconds without operation, if the password is correct, the code "d" will be displayed, otherwise it returns to the normal display.

(b) Press the "Set" key to convert the setup parameters, display the parameter code, press the "up" or "down" key to adjust the parameter value.

© Under the setup state, press "OK" or wait for 6 seconds without operation, it will automatically save the parameters and return to normal state.

5. One-click Restore of Preset Parameter

Under normal mode, hold "DOWN" key for 10s or more, the display screen flashes, and all parameters will be reset to factory settings. (Please make sure to record the set parameters in advance)

6. Stop/Silence buzzer alarm

Press any key to cancel the current buzzer alarm sound, but the indicator light will not turn off until the fault is removed.

7. Sterilization lamp operation

(a) When the instrument is running, single press the "disinfect" button, the light is on and it start disinfecting.

System menu

Parameter	Description	Setting range	Default setting	Remark
	Set water temp.	0 ~40.0°C	20.0°C	Water temperature display flashing
Strt (Note1)	Start-up time (hr)	0 ~ 23	0	Left Tube Flashing(hour)
Strt (Note1)	Start-up time (min)	0 ~ 59	0	Left Tube Flashing(minute)
SoPt (Note 2)	Shutdown time (hr)	0 ~ 23	0	Left Tube Flashing(hour)
SoPt (Note 2)	Shutdown time (min)	0 ~ 59	0	Left Tube Flashing(minute)
InIt	Time calibration (hr)	0 ~ 23	0	Left tube displays
InIt	Time calibration (min)	0 ~ 59	0	Right tube displays
CF	unit switch	°C/°F	°C	C is Centigrade F is Fahrenheit

Note: In the water temperature setting state, hold "Set" key for 6 seconds, it displays the password "pass", the setting menu will be displayed only by entering the correct password.

Parameter	Description	Setting range	Default setting	Remark
Pd	Password	0 ~ 999	0	exit when password is incorrect
d	temp. return difference	0.5 ~ 20.0°C	2.0°C	can keep the control temp. in a certain range with this parameter
Pt	compressor delay protection	1 ~ 5min	3min	To prevent the compressor start or stop frequently
Ca	temperature calibration	-15.0 ~ 15.0°C	0°C	To adjust the temp. when there is difference between the real and measured temperature
dC	defrost cycle	0 ~ 99hr	2	will not defrost when it is set to "0"
dEF	defrost mode	0 ~ 1	1	0 is natural defrost 1 is defrost with compressor
dt	defrost time	1 ~ 45min	10	-
drt	dripping time	0 ~ 15min	2min	-
bF	alarm buzzer	On/Off	On	-
Bp	key sound	On/Off	On	-

Note 1: When "Start time" is set to 0, the left digital tube displays "-----" for not automatic power-on, if not, the left digital tube displays the set power-on time, and the "Time" indicator is on.

Note 2: When "Stop time" is set to 0, it will not shut down automatically, the right digital tube displays the real time, if not, the left digital tube displays the set shutdown time, and the "Time" indicator lights.

⚠ : The start time and stop time can not be set to the same.

Wiring Diagram

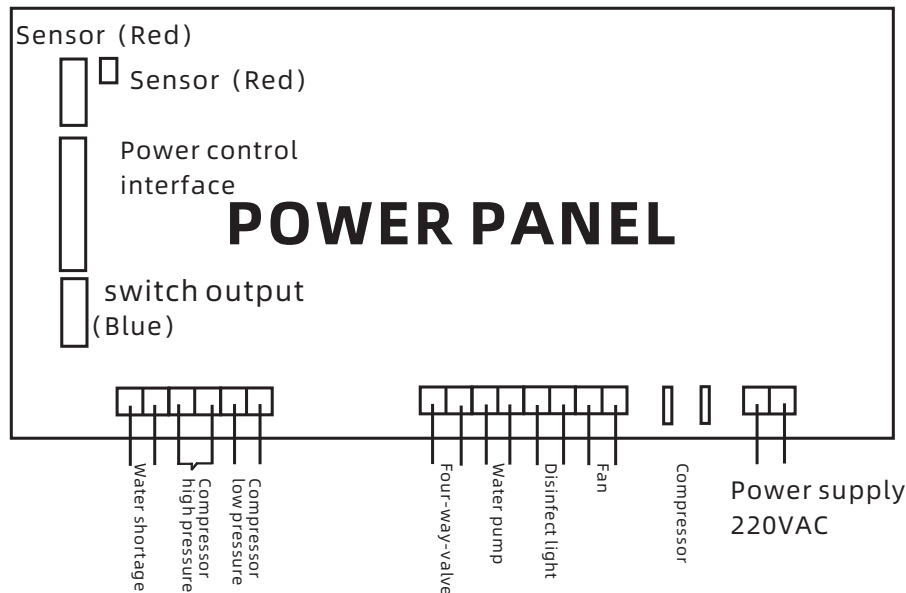
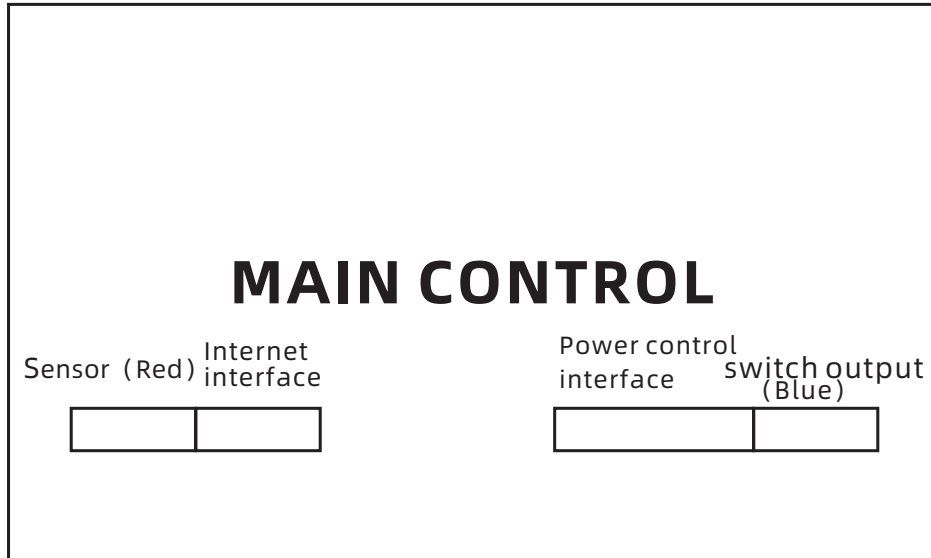

Running condition

1. Compressor

Running condition: stop time \geq (Pt) set time or water temperature \geq set temperature + temperature return difference or \leq set temperature - temperature return difference.

Stop condition: water temperature \geq set temperature.

2. fan: start and stop simultaneously with the compressor.

3. four-way valve: when the system is under heating state, four-way valve relay connects 10s before the compressor relay connects.

4. Pump:

the pump starts 2 minutes before the compressor starts, the pump stops with the compressor, if the pump stops working for 60 minutes and the compressor still does not reach the start-up conditions, then the pump will work independently for 5 minutes; if the compressor reach the start-up condition in 60 minutes, then the pump will work 2 minutes before the compressor works. The pump will stop working during the defrosting.

Fault handling

a) Sensor failure: Er1 alarm is displayed, buzzer sounds and all operations are stopped.

(b) Compressor high pressure failure: Er2 alarm is displayed, the buzzer sounds and all operations stop.

© Compressor low pressure failure: Er3 alarm is displayed, the buzzer sounds, all operations stop.

(d) Water shortage failure: Er4 alarm output, buzzer sounds, all operations stop.

Trouble shooting

Failures	Causes	Solutions
Without display	Check to see if the power is short circuit or the thermostat is faulty.	Check power supply if there is 220V power input.
With display but the load does not work	The set temperature is higher than the current temperature (cooling mode) The wiring is incorrect.	Reset the right temperature Check if it is overload or overheating. Check the wiring, make sure connect to the right terminals.
The current temperature is different from the real temperature	1. The locations of the sensors are incorrect or sensor wiring is extended too long. 2. The terminal wiring contact is poor 3. The sensor is damaged.	1. Sensors should be installed into the correct location. 2. Enlarge the cross section of the expanded wires. 3. Make sure the wiring is sealed properly, water-proof or moisture-proof. 4. Change sensor if necessary.
Compressor works with over-frequency	Return difference value is set too small	Reset the value of temperature return difference, normally is 2 to 3.
Machine does not stop when the temperature reaches set value	Check if the sensor has accurately measured the temperature or not. The relay of the compressor is malfunction.	Install the sensor correctly or check the sensor is damaged or not Check the relay of the compressor

Supplement

1. Please read this product instruction carefully and connect input/output plugs of power & sensor to the corresponding sockets strictly by following connection diagram strictly. Check again to make sure there is no mistake, tighten all the screw of connection plugs again, and then connect the power afterwards. Otherwise wrong connection will affect the usage and control, and even result in parts burning.
2. Keep this product from away moisture, corrosive air and high magnetic field. Otherwise the normal operation of this product will be affected.
3. All our products have passed strict quality inspections before leaving factory. We provide one-year quality guarantee (which is limited to product itself ,and is not responsible for any other joint and several liability) period for this product.
4. If the product has been damaged, including but not limited to the following types of damage not caused by the quality of the product itself
 - a) Installation and use in an unsafe environment;
 - b) The connected load capacity exceeds the permitted range of the product;
 - c) Disassembly and modification of the product by the user, replacement of internal components, etc;
 - d) The warranty date certificate on the product is an important basis for product quality assurance. Any replaced, damaged, scratched, defaced, lost, etc.We will not provide replacement or repair services for products damaged due to the above reasons, regardless of whether they are within the warranty period; and we will not be liable for any direct or indirect loss.

The code of the controller: digital tubes are flashing when the power is on, press the "disinfect" button, left digital tube shows first four characters, the right digital tube shows the last four characters.

For example: the left digital tube shows "0126", the right digital tube shows "3E06", then the machine's code is "01263E06".